

## 4-WHEEL CONTAINERS

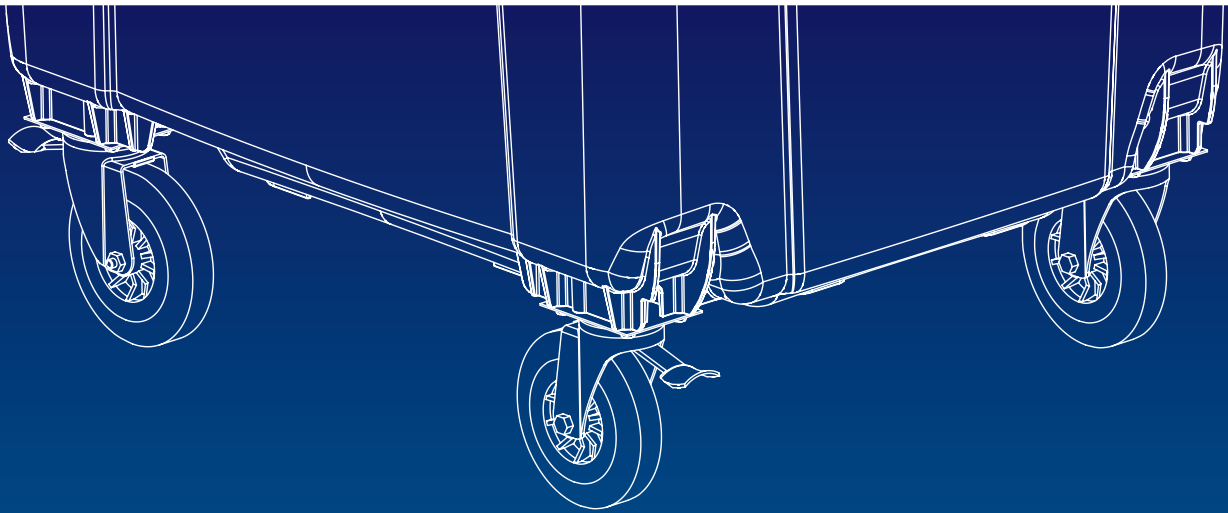

FLAT LID

500-1100 L



# EASY AND SAFE TO USE

## FLAT LID - HIGH STANDARD

Our range of 4-wheeled containers comes with a robust flat lid design. A simple hinge mechanism ensures maintenance-free use. Compact dimensions and easy handling make the containers suitable for various applications. An additional child safety lock is not required.

## COMPREHENSIVE STANDARD

- Reinforced body construction, particularly at the front and rear edges
- Base structure and high stress areas are computer-designed and tested for durability
- Lids have a side lip for automatic closing and positioning when on uneven ground
- Wide symmetrical trunnion retainer with reinforcement tubes
- Strong integrated lid pin
- Four ergonomic handles on the side as standard (two handles are exchangeable)
- DIN comb receiver with honeycomb ribbing
- Centrally positioned water drain plug secured against dropping
- Reinforced wheel housings
- Rounded corners at the base

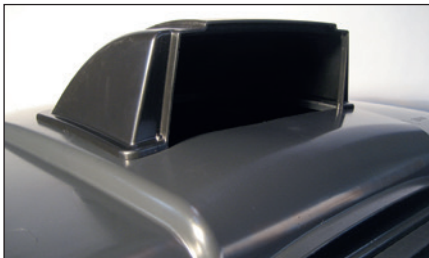

Optional paper hood



30° lid opener



Wide trunnion

## TECHNICAL DATA

MGB	500	660	770	1100
Nominal volume (l)	500	660	770	1100
Weight of container (kg)	38	40	43	50
Max. permissible weight (kg)	240	310	360	510
A Overall height (mm)	1135	1213	1365	1354
B Overall width (mm)	1360	1373	1373	1373
C Overall depth (mm)	655	780	776	1073
D Height to upper edge comb (mm)	1050	1088	1240	1206
E Wheel diameter	200	200	200	200

## SELECTION OF OPTIONS

- Locking devices
- Various recycling inserts
- Noise reduction
- Central brake system
- Heavy duty wheels
- Towing device
- Foot-operated lid opening
- Lid restrictor to 30° (Munich model)
- Identification systems

These details are subject to technical changes. For further options, please refer to our accessories brochure. The products contain no substances on the SVHC list of the European Chemicals Agency (ECHA).



660 L



770 L



1100 L

- Smooth surfaces for easy maintenance
- Eight ribs in the chip-nest secure the position of the transponder
- Colours: 16 standard colours; additional colours on request

### FUNCTIONAL AND CONFORMING TO STANDARDS

ESE always considers the entire logistic and application chain when designing products, including requirements for filling, emptying, handling and health and safety. The containers fulfil all current European and national standards and are certified in accordance with the highest quality standard worldwide, the RAL-GZ 951/1.

### UNIVERSAL EMPTYING

The flat lid containers can be emptied into front, rear and side loading vehicles using comb and trunnion retainers. The flat lid does not require a lid opener.

Special lifting devices are available on request.



Side handles replaceable



Computer-designed base construction



Reinforced wheel housing

### DIMENSIONS

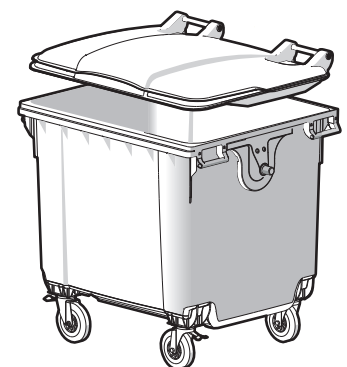
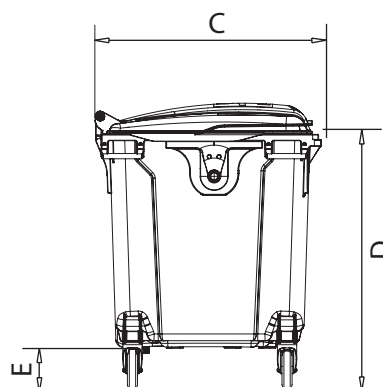
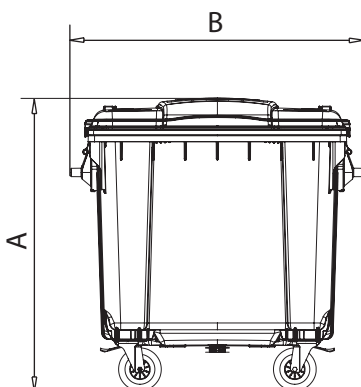

## ESE - WE VALUE YOUR RECYCLABLES



KERBSIDE SYSTEMS  
MOBILE CONTAINERS FOR  
WASTE AND RECYCLABLES



BRING SYSTEMS  
(SEMI-) UNDERGROUND SYSTEMS  
COLLECTION BANKS



BIO SELECT LINE  
CONTAINERS AND COMPOSTERS  
FOR GARDEN AND BIO WASTE



HAZARDOUS WASTE CONTAINERS  
MOBILE FUEL CONTAINERS  
MOBILE OIL CHANGE UNITS



PUBLIC FURNISHING  
BINS FOR THE PUBLIC SPACE



CONTAINER MANAGEMENT  
DISTRIBUTION, REGISTRATION,  
COLLECTION AND RECYCLING

ESE is Europe's leading manufacturer of temporary storage solutions for waste and recyclables. Our comprehensive range of products is complemented by a full service offer from container management to the recycling of products at the end of their lifetime. Specialists in all departments develop solutions to meet our customers' requirements. In doing so, we follow the principle of highest possible sustainability from product development and production to transport.